



DIECI

AGRI PIVOT | PIVOT

T50 | T60 | T80 | T90



WHERE THE OTHERS DON'T REACH

PIVOT: THE MOST VERSATILE

The articulated **large capacity** vehicle with telescopic boom which can satisfy every need. **Great agility, precise** movements, excellent **visibility**, maximum **power** to the wheels and to the boom, absolute **comfort**: are just some of the reasons that make Pivot essential. The new-generation ecological and high-performance engines, **with full electronic control**, deliver all the power you need with the **lowest fuel consumption in the category**.

COMPACT LINE



T50

- ↑ Height 4,7 m
- 📊 Capacity 2250 kg
- ⚡ Power 73 hp
- 🏠 Mass 6020 kg



T60

- ↑ Height 4,7 m
- 📊 Capacity 2250 kg
- ⚡ Power 73 hp
- 🏠 Mass 6020 kg

4.7 m **LOADING HEIGHT**

2250 kg **MAXIMUM CAPACITY**



HEAVY LINE



T80

- ↑ Height 5,2 m
- 📊 Capacity 3500 kg
- ⚡ Power 129 hp
- 🏠 Mass 8000 kg



T90

- ↑ Height 5,7 m
- 📊 Capacity 4100 kg
- ⚡ Power 138 hp
- 🏠 Mass 9800 kg

5.2-5.7 m **LOADING HEIGHT**

3500-4100 kg **MAXIMUM CAPACITY**



RELIABLE AND PRODUCTIVE

COMPACT, FLEXIBLE AND POWERFUL

The wide range of dedicated equipment and the high quality components ensure high level performance in all working conditions.

GREAT PERFORMANCE FOR GREAT RESULTS

Six models, all equipped with intuitive and advanced technologies, and a large control display that provides all operational information in real time.

CONCEPT

Hydrostatic transmission, articulation with **double central joint** with 80° total steering angle, **rear oscillating axle** with 25° total stroke, large output angle (>30°) and lifting moment limiting device, make Pivot an extremely manageable, reliable and safe vehicle.

EVOLUTION

SPEED

Up to 40 km/h with high traction force. **Powerful acceleration** and **easy driving**, in total safety.

INCHING PEDAL

Essential control when the forward speed must be reduced or stopped, and when the **maximum hydraulic power** is required for using the equipment. The servo-assisted service brake ensures **safe and modulated braking**, while reducing stress on the pedal.

FULL TRACTION CONTROL

The innovative electronic engine/transmission control system allows **progressive speed control** in all working conditions.



ISO 24410 UNIVERSAL MOUNTING FRAME

Available as an optional, in mechanical or hydraulic version, it allows the **complete interchangeability** of all the equipment normally used for Skid Loaders (only T50 T60 models).

OUTPUT ANGLE >30°

The large output angle >30° makes Pivot unstoppable, both on uneven ground and in earth moving operations: **there are no obstacles.**



COMFORT

ABSOLUTE COMFORT

The intelligently designed control layout makes the vehicle **simple, intuitive** and comfortable to use. Accessing the driving position will be easier and safe thanks to the **two large doors with 180° opening**. Inside the cab everything has been designed in order to make work easier for the operator. Unparalleled technology with the new **on-board computer**. The display shows clearly and in real time all the information necessary to operate the vehicle.

Soundproofing, adjustable steering wheel in both height and reach, storage compartments and various accessories such as radio, sun screen and **ergonomic seat with pneumatic suspension** allow to operate in conditions of total comfort. The Dieci research and development department designed the lowest cab in its category, keeping the driver's seat in raised position and obtaining a combination of perfect **visibility and compactness**.

Semi-automatic air conditioning system with 7 outlet vents, **sunroof** and total or partial opening of the 2 doors for better air circulation during work.

The curved front glass, the wiper that cleans its upper part, the **large windows** and the raised driving position provide an **unparalleled 360°** view even when the boom is raised.

360° VISIBILITY

ON-BOARD COMPUTER

A/C

HANDLING

ALL THE CONTROLS IN ONE HAND

The **new 4-in-one joystick**, standard on all models, provides integrated control of the vehicle. The optional **integrated travel direction control** allows rapid shuttling between forward and reverse.

The compensated **flow sharing control valve** allows simultaneous operation of all movements.

EASY DUMPING

The exclusive and **compact swing kinematic mechanism**, specifically designed to increase the service angle, is particularly appreciated when the bucket is moved to the ground and when it is unloaded at the maximum height.

AGILITY

The high-efficiency steering system transmits an easy **driving** sensation even under the highest load conditions. The steering occurs through 2 hydraulic cylinders which make the maneuver uniform and compact in both directions.

EASY RIDE

Developed by Dieci design engineers, the sophisticated **pneumo-hydraulic suspension system installed on the boom** (optional) drastically reduces oscillation when traveling over rough terrain.



WIDE TURNING RADIUS

EASY DUMPING

EASY RIDE

NEW JOYSTICK

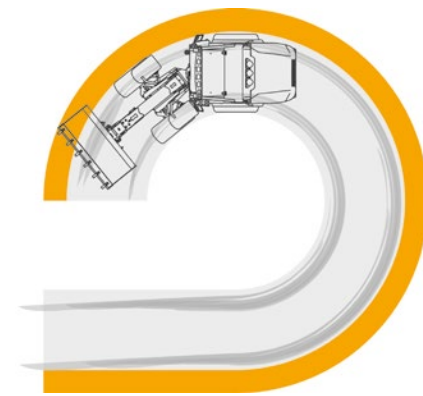

FOOTPRINT = PASSAGE DIMENSIONS

The central articulation system was designed by Dieci technicians with craftiness and intelligence, allowing an **excellent control when maneuvering**.

The vehicle overall dimension is always determined by the front or rear wheels, ensuring the operator that rear side will not hit while maneuvering.



DPF AND SCR WITH ADBLUE

Dieci has chosen to use a totally electronic control for injection, turbo pressure, torque, rpm, engine brake, starter safety release, monitoring, diagnostics. Furthermore, the **DPF** and **SCR** technologies **with AdBlue** for the exhaust gases treatment allow Pivot to comply with the environmental regulations. Thanks to this innovative engine generation, **higher performance** means **lower fuel consumption**, lower engine oil contamination and longer maintenance intervals.



GREEN CORE

Turbo Aftercooler Common Rail Diesel engines with full electronic control.

Significant reduction in fuel consumption and longer intervals between services.

Updated with the latest regulations, emissions reduced by up to 90%, thanks to the particulate reduction, and 50% less nitrogen oxides.

SCR

DPF

-20% FUEL CONSUMPTION

NEW ENGINES

PIVOT SYSTEM

DOUBLE PIVOT JOINT

The staff of Dieci engineers obtained exceptional results for the central double-joint articulation with **80° steering angle**. The two joints give **exceptional stability and strength** even in extreme situations, without undergoing deformation. Cardan shaft and wiring are protected, inside the joint, from accidental impacts. The **flat bottom** allows safe working on any ground.

All the pins and bushings inserted in the Pivot joint are lubricated with grease, with **very high resistance** and sealing is ensured by the **Long Life** gaskets.

CENTRAL BOOM

DOUBLE PIVOT JOINT

REAR OSCILLATING AXLE



REAR OSCILLATING AXLE

This system allows a perfect adaptability to all types of ground, always guaranteeing **four support points** while maintaining the **maximum lateral stability** as on level ground.

Rear oscillating axle, output angle >30°, boom in central position and **many stability sensors**, allow the operator to perform extreme maneuvers in totally safe conditions.



TECHNOLOGY

HYDRAULIC SYSTEM

The new hydraulic pump with flow rates from 101 to 150 l/1' guarantee **higher maneuvering speed**, reducing the operating times by up to 20%.

ON-BOARD COMPUTER

Advanced instrumentation with a large display and **intuitive icon-based interface** provides comprehensive and detailed information. Constant monitoring of operating conditions and **in-depth diagnostics** using **real-time** data.

CAMERA

The cameras (optional) provide a millimetric view on the screen facilitating the loading and movement operations: **maximum control**.

QUICKDEP

System for depressurising the hydraulic sockets that makes the **connection of equipment easy and effortless**.

CAMERA

QUICK DEP

ON-BOARD COMPUTER

POWER INSIDE

CYLINDER INSIDE THE BOOM

The boom, positioned centrally compared to the vehicle, and the extension cylinder, arranged inside it, guarantee **better visibility**, **without the risk** of accidental impacts.

EQUIPMENT PARALLELISM

The **compensation system** allows to automatically maintain the equipment parallel to the ground during the boom lifting and lowering operations.



MAINTENANCE

EASY MAINTENANCE

All available spaces are well exploited, to facilitate housing the fuel and AdBlue tanks in safe and accessible locations. **Practical interventions for routine engine maintenance**, facilitated by the **concealed hood opening**.

1000 HOURS

Engine oil change every 500 hours. Scheduled maintenance interventions for all parts, such as filters and moving parts, every 1000 hours. **Longer work cycles**, fewer interruptions, **greater productivity**.

SAFETY

ROPS-FOPS

ROPS-FOPS approved cab designed with **safety cell** to prevent deformation in the event of vehicle tipping or if a heavy load falls on the cab.

ANTI-TIPPING SYSTEM

Every Dieci machine is equipped with a **lifting moment limiting device** that analyzes the vehicle stability in real time and inhibits any aggravating movements when the preset safety limits are reached.

Hydraulic servo brake as standard on all models, to facilitate stopping operations in the most extreme conditions.

The Joystick is equipped with a capacitive deadman sensor which, combined with the **operator presence sensor** in the seat, prevents accidental operation.

STURDY CHASSIS

The chassis, with a strong visual impact, unmistakably characterizes Pivot. The oversized structure provides **rigidity and total safety**, even under the most stressful conditions. The vehicle is totally **free of vibration and flexure**.



DIECI SERVICE

Dieci Service is our technical assistance service present across the world, through an **extensive network of dealers** and authorized service centers. Our customers are assisted directly by specialized technicians and every request is satisfied in a very short time: thanks to the use of automated warehouses, Dieci Service can provide, within a few hours, interventions and spare parts all over the world.

Visit www.dieci.com to find the dealer closest to you.

DEALERS 400

COUNTRIES 70

BRANCHES 3

TECHNICAL DATA *COMPACT LINE*

PERFORMANCE

Machine model	T50	T60
Operating weight with standard bucket and quick coupling	6020 kg (13272 lb)	6020 kg (13272 lb)
Standard bucket capacity	0,85 m³ (30 ft³)	0,85 m³ (30 ft³)
Pull-out force	4800 daN (10791 lbf)	4800 daN (10791 lbf)
Towing force	4600 daN (10341 lbf)	5700 daN (12814 lbf)
Maximum climb angle	70%	80%
Max speed (referred to wheels with maximum permitted diameter)	30 km/h (18,6 mph)	40 km/h (24,9 mph)
Retracted in line tipping load	4050 kg (8929 lb)	4050 kg (8929 lb)
Retracted articulated tipping load	3575 kg (7882 lb)	3575 kg (7882 lb)
Extended in line tipping load	2350 kg (5181 lb)	2350 kg (5181 lb)
Extended articulated tipping load	2050 kg (4519 lb)	2050 kg (4519 lb)
Operating load EN474.3 (80%) retracted	2250 kg (4960 lb)	2250 kg (4960 lb)
Operating load EN474.3 (60%) retracted	1700 kg (3748 lb)	1700 kg (3748 lb)
Operating load EN474.3 (80%) extended	1400 kg (3086 lb)	1400 kg (3086 lb)
Operating load EN474.3 (60%) extended	1050 kg (2315 lb)	1050 kg (2315 lb)

ENGINE

Machine model	T50	T60
Brand	Kubota	Kubota
Nominal power	54,6 kW (73 HP)	54,6 kW (73 HP)
@rpm	2600 rpm	2600 rpm
Displacement	3331 cm³ (203 in³)	3331 cm³ (203 in³)
Emission standards	Stage V/Tier 4f	Stage V/Tier 4f
Exhaust gas treatment	Particulate filter (DPF)	Particulate filter (DPF)
Intake	Turbo compressor	Turbo compressor

TRANSMISSION

Machine model	T50	T60
Transmission type	Hydrostatic with variable displacement pump	Hydrostatic with variable displacement pump
Hydraulic motor	Hydrostatic with continuous automatic adjustment	Hydrostatic with continuous automatic adjustment
Transmission gearbox	Single speed Dropbox	Servo-controlled 2-speed
Inching	With hydraulic pedal for controlled forward movement	With hydraulic pedal for controlled forward movement

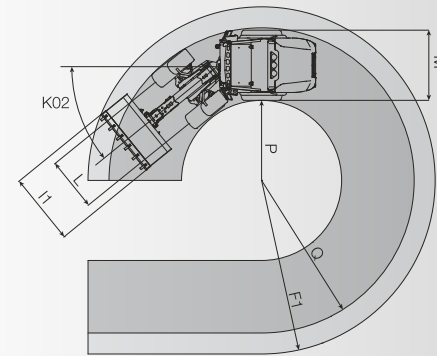
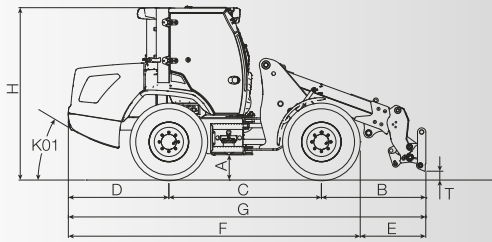
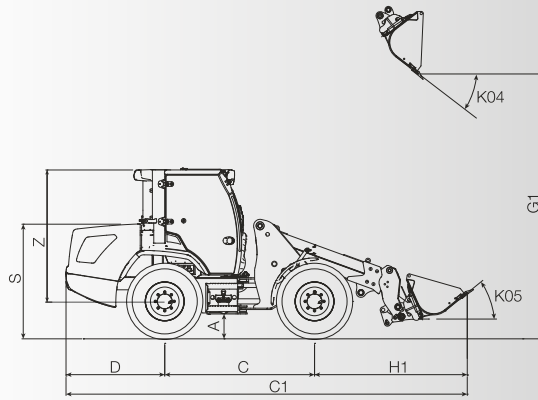

HYDRAULIC SYSTEM

Machine model	T50	T60
Hydraulic pump type	Gear pump for power steering and movements	Gear pump for power steering and movements
Hydraulic pump capacity	101 L/min (26,7 gal/min)	101 L/min (26,7 gal/min)
Max. operating pressure	23,0 MPa (3336 psi)	23,0 MPa (3336 psi)

DIMENSIONS

Machine model	T50	T60
A	365 mm (14,4 in)	365 mm (14,4 in)
B	1750 mm (68,9 in)	1750 mm (68,9 in)
C	2200 mm (86,6 in)	2200 mm (86,6 in)
C1	6015 mm (236,8 in)	6015 mm (236,8 in)
D	1450 mm (57,1 in)	1450 mm (57,1 in)
E	1190 mm (46,9 in)	1190 mm (46,9 in)
F	4210 mm (165,7 in)	4210 mm (165,7 in)
F1	4670 mm (183,9 in)	4670 mm (183,9 in)
G	5400 mm (212,6 in)	5400 mm (212,6 in)
G1	4155 mm (163,6 in)	4155 mm (163,6 in)
H	2490 mm (98 in)	2490 mm (98 in)
H1	2365 mm (93,1 in)	2365 mm (93,1 in)
I1	2000 mm (78,7 in)	2000 mm (78,7 in)
L	1430 mm (56,3 in)	1430 mm (56,3 in)
M	1880 mm (74 in)	1880 mm (74 in)
P	2060 mm (81,1 in)	2060 mm (81,1 in)
Q	4010 mm (157,9 in)	4010 mm (157,9 in)
S	1699 mm (66,9 in)	1699 mm (66,9 in)
T	93 mm (3,7 in)	93 mm (3,7 in)
Z	1962 mm (77,2 in)	1962 mm (77,2 in)
K01	31°	31°
K02	40°	40°
K04	40°	40°
K05	40°	40°

MAX
2,25 t

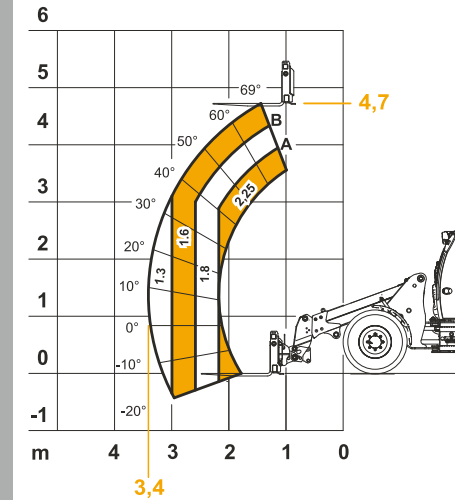

EN474-3 (ISO14397)

T50

MAX
2,25 t

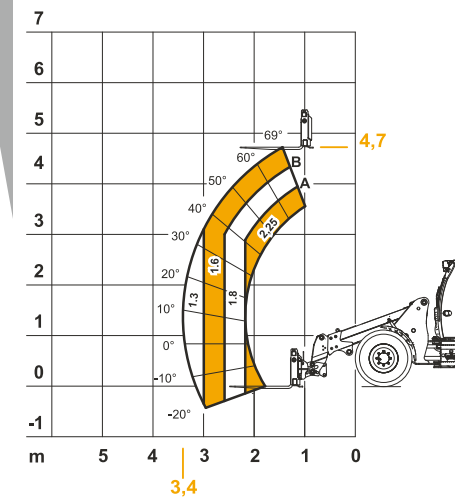

EN474-3 (ISO14397)

T60

TECHNICAL DATA *HEAVY LINE*

PERFORMANCE

Machine model	T80	T90
Operating weight with standard bucket and quick coupling	8000 kg (17637 lb)	9800 kg (21605 lb)
Standard bucket capacity	1,20 m³ (42 ft³)	1,25 m³ (44 ft³)
Pull-out force	6700 daN (15062 lbf)	7470 daN (16793 lbf)
Towing force	6500 daN (14613 lbf)	8450 daN (18996 lbf)
Maximum climb angle	60%	80%
Max speed (referred to wheels with maximum permitted diameter)	36 km/h (22,4 mph)	40 km/h (24,9 mph)
Retracted in line tipping load	6100 kg (13448 lb)	6100 kg (13448 lb)
Retracted articulated tipping load	5400 kg (11905 lb)	5400 kg (11905 lb)
Extended in line tipping load	3200 kg (7055 lb)	3250 kg (7165 lb)
Extended articulated tipping load	2800 kg (6173 lb)	2900 kg (6393 lb)
Operating load EN474.3 (80%) retracted	3500 kg (7716 lb)	4100 kg (9039 lb)
Operating load EN474.3 (60%) retracted	2600 kg (5732 lb)	3050 kg (6724 lb)
Operating load EN474.3 (80%) extended	1800 kg (3968 lb)	2000 kg (4409 lb)
Operating load EN474.3 (60%) extended	1400 kg (3086 lb)	1500 kg (3307 lb)

ENGINE

Machine model	T80	T90
Brand	FPT	FPT
Nominal power	96 kW (129 HP)	103 kW (138 HP)
@rpm	2200 rpm	2200 rpm
Displacement	4485 cm³ (274 in³)	4485 cm³ (274 in³)
Emission standards	Stage IV/Tier 4f	Stage IV/Tier 4f
Exhaust gas treatment	DOC+SCR (AdBlue)	DOC+SCR (AdBlue)
Intake	16-valve turbo compressor, after-cooler	16-valve turbo compressor, after-cooler

TRANSMISSION

Machine model	T80	T90
Transmission type	Single speed Hydrostatic transmission with variable displacement pump	Hydrostatic Vario System EVO2 electronically controlled with 2 hydrostatic motors with continuous automatic adjustment
Hydraulic motor	Hydrostatic with continuous automatic adjustment	-
Transmission gearbox	Single speed Dropbox	-
Inching	Pedal inching for controlled forward movement	With electronic pedal for controlled forward movement

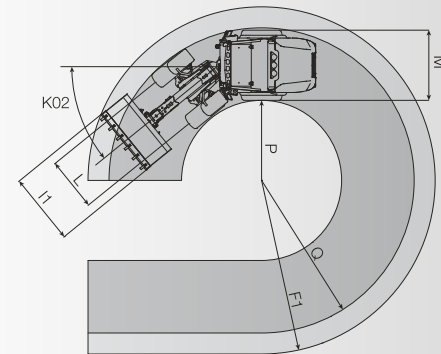
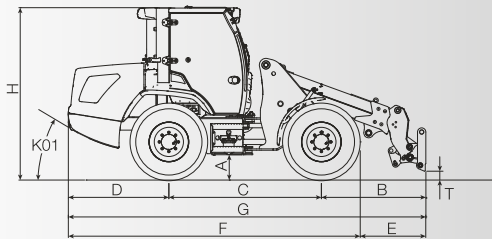
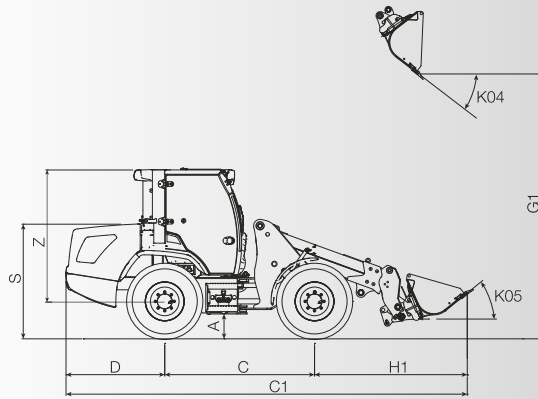

HYDRAULIC SYSTEM

Machine model	T80	T90
Hydraulic pump type	Gear pump for power steering and movements	Piston pump with variable displacement for power steering and movements.
Hydraulic pump capacity	114 L/min (30,1 gal/min)	150 L/min (39,6 gal/min)
Max. operating pressure	25,0 MPa (3626 psi)	26,0 MPa (3771 psi)

DIMENSIONS

Machine model	T80	T90
A	400 mm (15,7 in)	351 mm (13,8 in)
B	1670 mm (65,7 in)	1898 mm (74,7 in)
C	2550 mm (100,4 in)	2800 mm (110,2 in)
C1	6760 mm (266,1 in)	7423 mm (292,2 in)
D	1675 mm (65,9 in)	1739 mm (68,5 in)
E	1030 mm (40,6 in)	1898 mm (74,7 in)
F	4865 mm (191,5 in)	5207 mm (205 in)
F1	5300 mm (208,7 in)	5906 mm (232,5 in)
G	5895 mm (232,1 in)	6440 mm (253,5 in)
G1	4400 mm (173,2 in)	4839 mm (190,5 in)
H	2680 mm (105,5 in)	2790 mm (109,8 in)
H1	2520 mm (99,2 in)	2884 mm (113,5 in)
I1	2200 mm (86,6 in)	2400 mm (94,5 in)
L	1790 mm (70,5 in)	1790 mm (70,5 in)
M	2250 mm (88,6 in)	2400 mm (94,5 in)
P	2500 mm (98,4 in)	2743 mm (108 in)
Q	4750 mm (187 in)	5193 mm (204,4 in)
S	1937 mm (76,3 in)	1990 mm (78,3 in)
T	201 mm (7,9 in)	192 mm (7,6 in)
Z	2106 mm (82,9 in)	2170 mm (85,4 in)
K01	30°	32°
K02	40°	40°
K04	40°	37°
K05	40°	38°

MAX
3,5 t

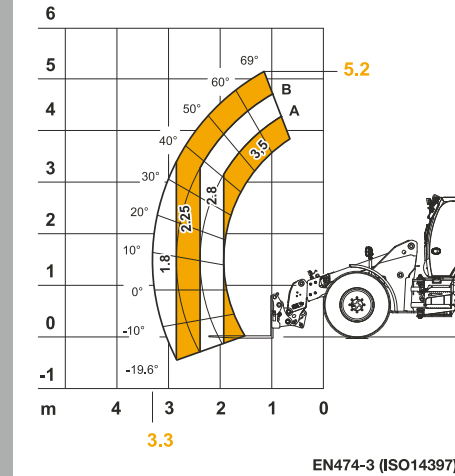

T80

MAX
4,1 t

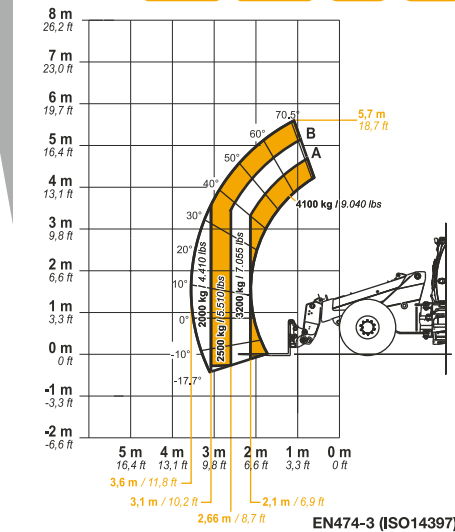

T90

DIECI, A STRONG COMPANY

EXPERIENCE FOR INNOVATION

We design and build work vehicles since 1962, and today we are recognized as one of the most important global players.

Proudly Italian, with general headquarters in Emilia Romagna of over 135,000 square meters and about 400 people employed, thanks to 3 European branches in Germany, United Kingdom, France and a global network of over 400 dealers, Dieci is present in over 70 countries.

Research and development of innovative technologies, training and customer care are incessantly at the center of our activities: the result of this constant commitment is realized in an offer that includes 159 models in production, including construction, agricultural, industrial and special vehicles.

In the last 2 years we have renewed 80% of the product range, to offer our customers increasingly advanced, performing, reliable and safe solutions.

We have made important upgrades on comfort and design, to **give value to the most important element for us: man.**

1962 **FOUNDED**

135.000 **m²**

400 **EMPLOYEES**

159 **MODELS**

19 **FAMILIES**



AGRI PIVOT | PIVOT

T50 | T60 | T80 | T90

dieci

www.dieci.com

